

## NEW ULTRA HIGH-SPEED CIRCUIT TECHNIQUES WITH ANALOG ICs

By Christian Henn, Burr-Brown International GmbH

With the increasing use of current-feedback amplifiers, the Diamond Structure has come to play a key role in today's analog circuit technology. Two new macro elements that function in this structure are the Diamond Transistor and its abridged version, the Diamond Buffer. These elements can be used for both voltage and current control of analog signals up to several 100MHz. The OPA660 combines both of these elements in one package. Starting with a discussion of the technical process requirements for complementary-bipolar circuit technology, we would like to focus on the basic and functional circuits of the Diamond Transistor and Buffer. These circuits can be used in areas ranging from video signal processing and pulse processing in measurement technology to interface modules in fiber optic technology.

### SYMBOLS AND TERMS

In technical literature, various symbols and terms are used to describe the same circuit structure, see Figure 1. Burr-Brown has chosen the transistor symbol with opposed emitter arrows. The symbol calls attention to the functional similarity of the bipolar and Diamond Transistors, and the double arrows refer to the Diamond Transistor's complementary construction and the ability to operate it in four quadrants. Regardless of how it is depicted, this type of structure has a high-impedance input, a low-impedance input/output, high transconductance and a high-impedance current source output. The voltage is transferred with very low offset of +7mV from the high-impedance input to the low-impedance input/output.

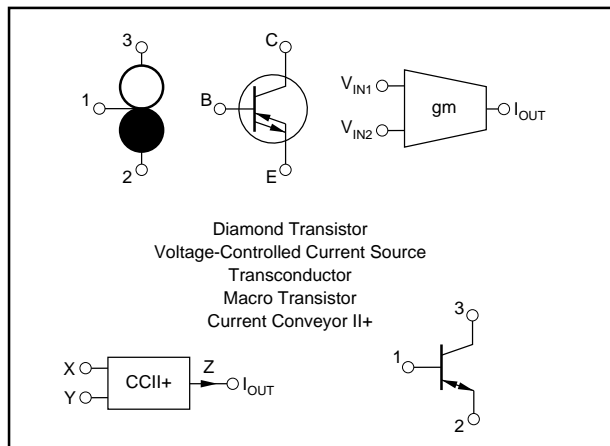

FIGURE 1. Symbols and Terms.

### TECHNICAL PROCESS REQUIREMENTS FOR COMPLEMENTARY CIRCUIT TECHNIQUES

Circuits implemented in push-pull arrangements, in which both NPN and PNP transistors are located in the signal path, demand a particular high level of symmetry in the electrical parameters of complementary transistors. See Figure 2.

The most important requirement is that the bandwidths be equal, since the slower transistor type determines the performance capability of the entire circuit. The bandwidth of an integrated bipolar transistor is dependent both upon the base transit time and upon various internal transistor resistances and p-n junction capacitances.

Another important point is the DC performance, which can be described best by the parameters saturation current  $I_s$ , current gain  $\beta F$  and early voltage. The Diamond Transistor and buffer are manufactured using a complicated process with vertically structured NPN and PNP transistors. Table I shows the most important parameters of a transistor of size 111. Two metallization layers with a gold surface simplify the connection between the circuit parts.

### APPLICATION EXAMPLES

- Wide-bandwidth amplifiers
- Video signal processing
- Pulse processing in radar technology
- Ultrasonic technology
- Optical electronics
- Test and communications equipment

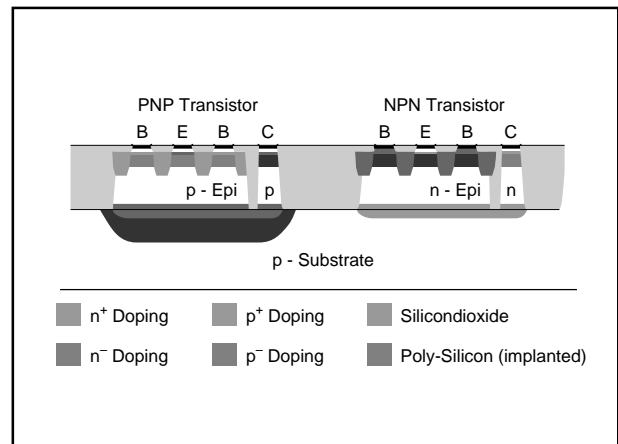

FIGURE 2. Complementary Bipolar Technique (CBip).

PARAMETER	NPN	PNP	DIM
Current Gain	220	115	
Early voltage	66	30	V
$C_{JS}$	0.26	0.50	pF
$C_{JE}$	0.02	0.02	pF
$R_B$	540	429	$\Omega$
$R_C$	46	43	$\Omega$
Transit Frequency	3.5	2.7	GHz
<ul style="list-style-type: none"> <li>• symmetric NPN/PNP pairs</li> <li>• complex process sequence</li> <li>• n-cube</li> <li>• p<sup>+</sup> and n<sup>+</sup> buried layer</li> <li>• n-epitaxy, p-collector implantation</li> <li>• complementary B/E structures</li> <li>• isolation variations</li> </ul>			

TABLE I. Process Parameter.

### SIMPLIFIED CIRCUIT DIAGRAM OF THE DIAMOND TRANSISTOR

The OPA660, Figure 3, is a new type of IC which can be used universally. It consists of a voltage-controlled current source (Diamond Transistor), a complementary offset-compensated emitter follower (buffer amplifier, Diamond Buffer), and a power supply. This new IC enables users to adjust the quiescent current, and through its temperature characteristics, it maintains a constant transconductance in the Diamond Transistor and Buffer. The emitter follower functions without feedback. For this reason, its gain is somewhat less than one and is slightly dependent upon the load resistance. The main task of the emitter follower is to decouple signal processing stages.

It is distinguished by its extremely short delay time of 250ps and an excellent large-signal bandwidth/quiescent current ratio. When comparing the Diamond Buffer with the Diamond Transistor, it becomes apparent that all aspects of the components are identical except for the current mirror. The Diamond Buffer can thus be called an abridged version of the Diamond Transistor.

The Operation Transconductance Amplifier section, or OTA, will be referred to as the Diamond Transistor in the following. Its three pins are named base, emitter, and collector, like the pins of a bipolar transistor. This similarity in terms points to the basic similarity in function of the two transistors. Ideally, the voltage at the high-impedance base is transferred to the emitter input/output with minimal offset voltage and is available there in low-impedance form. If a current flows at the emitter, then the current mirror reflects this current to the collector by a fixed ratio. The collector is thus a complementary current source, whose current flow is determined by the product of the base-emitter voltage and the transconductance. Because of the PTAT (Proportional to Absolute Temperature) power supply, the transconductance is independent of temperature and can be adjusted by an external resistor.

Besides these features, the Diamond Transistor and Buffer can process frequencies of up to several 100MHz with very low errors in the differential phase and gain. Thus, they are universal basic elements for the development of complex circuits designed to process fast analog signals. Current control, voltage control, and operation with or without feedback are all possible with the Diamond Transistor and Buffer. See Table II.

PARAMETER	UNIT
DT Transconductance	125mA/V
Offset Voltage	+7mV
Offset Drift	50 $\mu$ V/ $^{\circ}$ C
Input Bias Current	2.1 $\mu$ A
Output Bias Current	$\pm$ 10 $\mu$ A
Input Resistance	1M $\Omega$    2.1pF
Output Resistance	25k $\Omega$    4.2pF
Differential Gain	0.06%
Differential Phase	0.02%
Quiescent Current	1-20mA

TABLE II. Diamond Transistor Parameter.

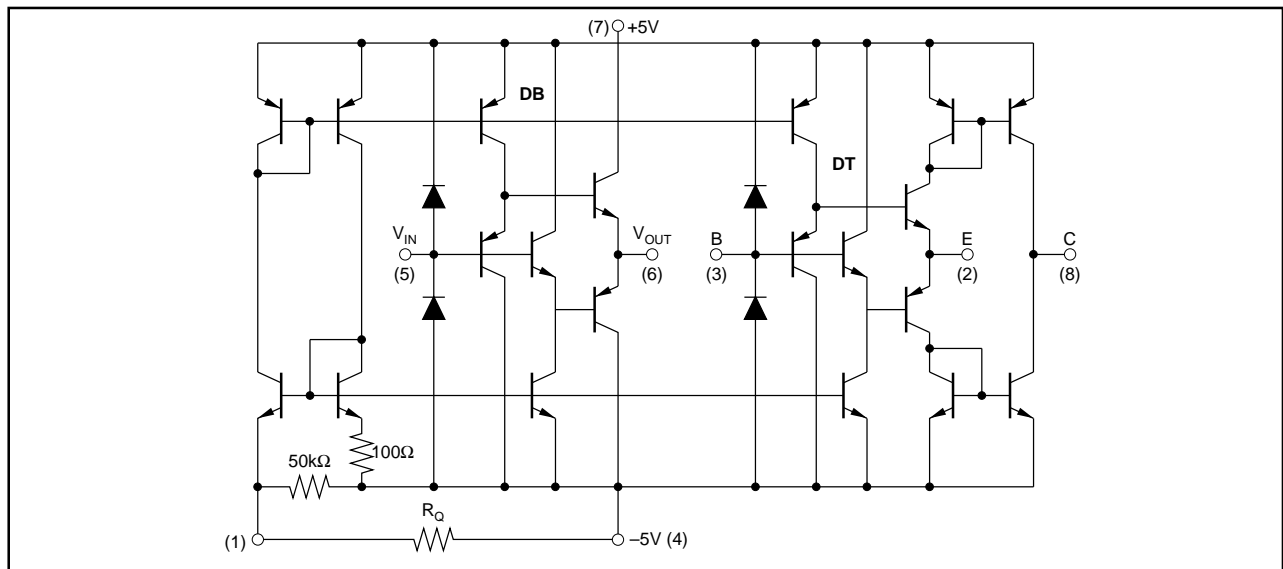

FIGURE 3. OPA660 Schematic.

### PTAT POWER SUPPLY

PTAT biasing-controlled current source with adjustable quiescent current, Figure 4.

Each individual transistor stage has a current source as the load impedance. Thus, control of the current source allows adjustment of the quiescent current. The adjusted quiescent currents and the transistors used determine the transconductance of the entire circuit. An external resistor,  $R_Q$ , fixes the quiescent current. We will discuss the exact equations for the ratio of the quiescent currents  $R_Q$  and transconductance to  $I_Q$  in detail later in this paper.

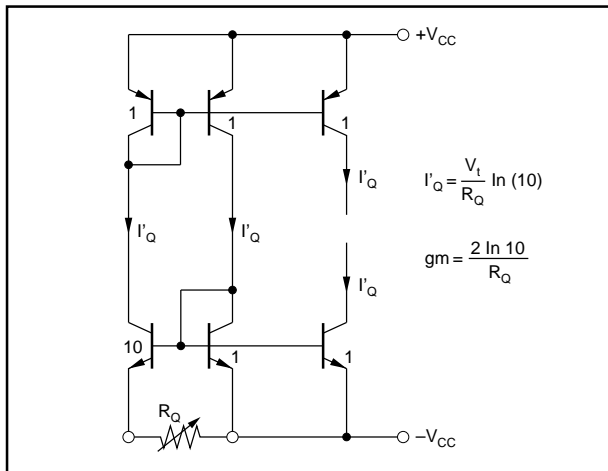

FIGURE 4. PTAT Power Supply.

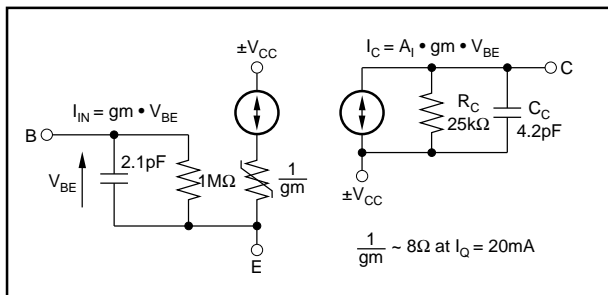

FIGURE 5. Equivalent Circuit.

### EQUIVALENT CIRCUIT DIAGRAM

The user can construct a simple equivalent circuit diagram, Figure 5, for the Diamond Transistor based on the previous descriptions. The complementary emitter follower with an input impedance of  $1M\Omega \parallel 2.1pF$  at the base pin can be regarded as a controlled voltage source. Using the fact that an emitter follower is, in principle, a voltage-controlled current source whose current flow is dependent upon the voltage difference between base and emitter, it is possible to determine the output resistance of the emitter. The output resistance can best be approximated as the reciprocal value of the transconductance. A quiescent current set at 20mA results in a transconductance of 125mA/V and a low-impedance output resistance of  $8\Omega$ , which is adjustable but stable with temperature. The collector pin performs like a complementary current source, with output impedance  $25k\Omega \parallel 4.2pF$ . The possible positive or negative current flow results from the product of the input voltage difference times transconductance times current mirror factor, which is fixed at  $A_1 = 1$  in the OPA660. The model presented here shows the similarity to the small-signal behavior of the bipolar transistor.

### OPA660 BASIC CONNECTIONS AND PINOUT CONFIGURATION

For trouble-free operation of the OPA660, several basic components on the power supply, as well as those components which define function, are necessary. See Figure 6. The triple configuration of the supply decoupling capacitors at pins 4 and 7 guarantees a low-impedance supply up to 1GHz and supplies the IC during large-signal high-frequency operation. The voltage supply is  $\pm 5V$ , resulting in a maximum rated output of  $\pm 4V$ . As already mentioned, the external resistor  $R_Q$  between pin 1 and  $-5V$  adjusts the quiescent current. A resistance value of  $250\Omega$  results in a quiescent current of 20mA. Process variations can cause this current to vary between 16mA and 26mA. The product data sheet illustrates the exact relation between  $R_Q$  and  $I_Q$ . As in discrete HF (high-frequency) transistors, a low-impedance resistor damps oscillation that might arise at the inputs. The circuit consists of the pin capacitances and inductances of the bond wires. The resonant frequency is between 750MHz

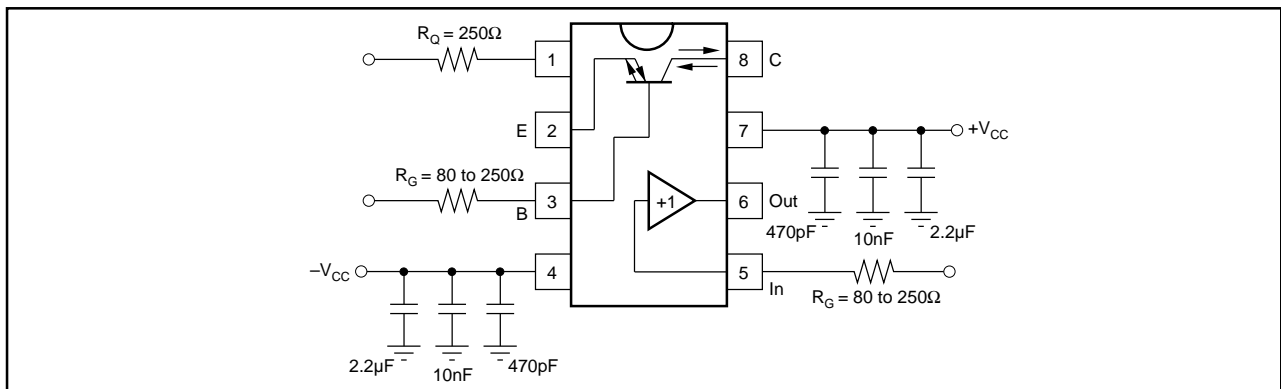

FIGURE 6. OPA660 Basic Connection

and 950MHz, depending upon the package type and layout, and is outside the operating range. The damping resistance is between 50Ω and 500Ω, depending upon the application.

### TEST CONFIGURATION FOR DETERMINING THE DYNAMIC FEATURES OF THE DIAMOND TRANSISTOR

Figure 7 shows the test configuration to determine the dynamic features of the Diamond Transistor. The entire test system functions as a 50Ω transmission system to avoid reflections from the input resistances. Various signal generators and indicators can be used depending upon the measurement task. The layout of the demo boards used here is designed for minimum line length and stray capacitance and uses the three-level combination of supply decoupling capacitors and 50Ω HF-connectors. Burr-Brown offers these demo boards to support design engineers during the test phase.

### FUNCTION DIAGRAMS

The diagrams introduce two important characteristics that help engineers to understand how the Diamond Transistor functions as a voltage-controlled current source with adjustable quiescent current.

Figure 8a shows the transfer curve  $I_O/V_{BE}$  with the quiescent current as a parameter. The transconductance increases with increasing quiescent current.

Figure 8b illustrates the transconductance dependency upon the input voltage. It is clear from this diagram that the transconductance of the Diamond Transistor remains more stable over the whole input voltage range than that of a bipolar transistor.

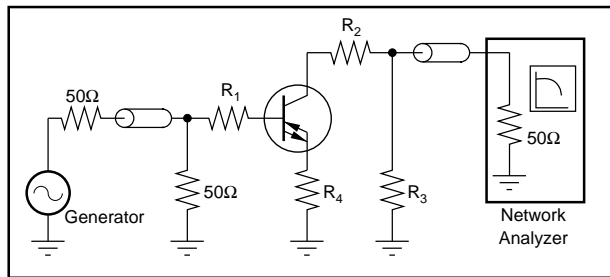

FIGURE 7. Test Circuit OTA.

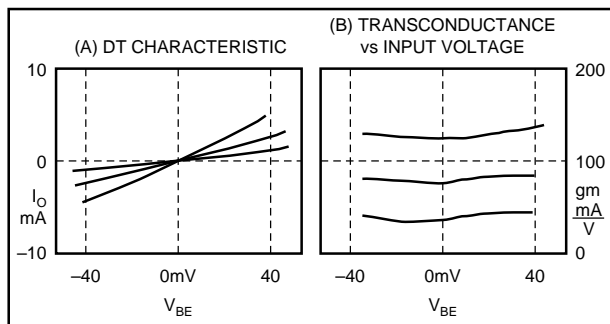

FIGURE 8. OTA Transfer Characteristics.

### BASIC CIRCUITS WITH THE OPA660

Listed below are the basic circuits possible with the Diamond Transistor:

- Emitter Circuit
- Base Circuit
- Common Emitter
- Common Emitter with Doubled Output Current
- Current-Feedback Amplifier
- Direct-Feedback Amplifier

As already mentioned, the signal transmission of the Diamond Transistor is the inverse of that of the bipolar transistor. The emitter circuit functions in non-inverting mode and the base circuit in inverting mode.

The emitter-collector connection enables the user to increase the output current of the emitter follower. Since both currents flow in the same direction and the current loop factor  $A_I$  of the OPA660 equals 1, the output current doubles to  $\pm 30\text{mA}$  and the output resistance halves. See Figure 9.

In many applications, the high-impedance collector output is a disadvantage. One possible solution to this problem is to insert the complementary emitter follower between the collector and the output. The emitter follower then ensures that the load resistance of the collector pin is high and that the output of the circuit can drive low-impedance loads. See Figure 10.

The inverting base circuit has a low-impedance input. This current input has clear advantages in amplifying outputs of sensors which deliver currents instead of voltages.

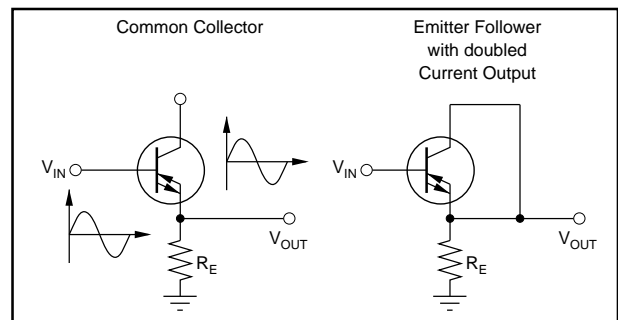

FIGURE 9. Emitter-Collection Connection.

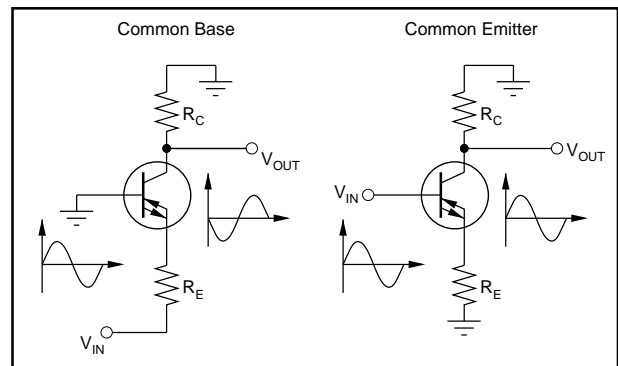

FIGURE 10. Emitter Follower.

$V_{OUT}$	$f_{-3dB}$
$\pm 100mV$	351MHz
$\pm 300mV$	374MHz
$\pm 700mV$	435MHz
$\pm 1.4V$	460MHz
$\pm 2.5V$	443MHz

TABLE III. -3dB Bandwidth vs Output Voltage.

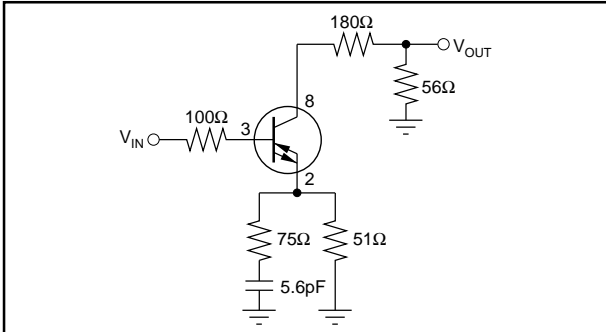

FIGURE 11. Straight Forward Amplifier.

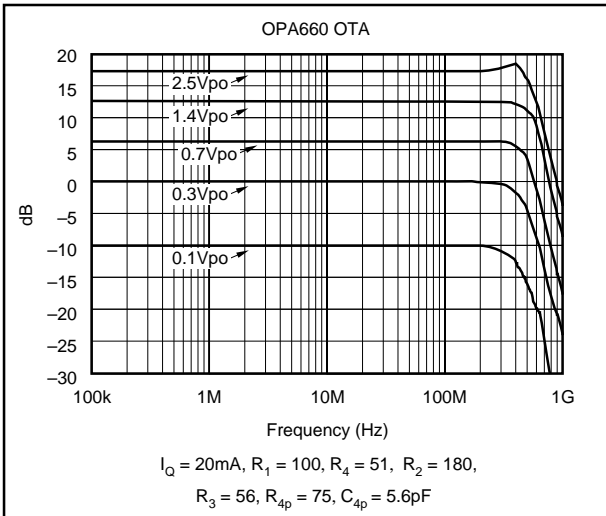

FIGURE 12. Straight-Forward Amplifier Frequency Response.

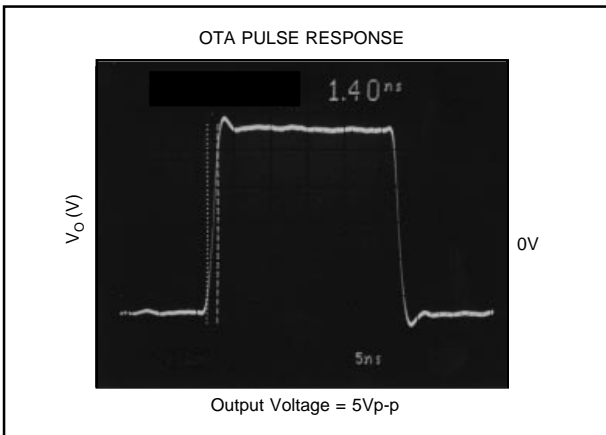

FIGURE 13. Pulse Behavior of a Straight-Forward Amplifier with Compensation.

Figures 11 through 13 show the frequency response attained with a gain of 3.85 and the pulse response achieved with an input pulse rise time of 1.3ns of the open-loop amplifier illustrated in the diagram below. We call this open-loop amplifier a “straight forward amplifier.”

With a quiescent current of 20mA and the applied component values, the -3dB bandwidth of the open-loop amplifier is between 350MHz at  $\pm 100mV$  and 460MHz at  $\pm 1.4V$ , depending upon the output voltage. See Table III.

The rise/fall time at the output is 1.4ns, and the maximum overshoot is under 10% and settles to less than 1% after 5ns. The settling time at 0.1%/10-bit is 25ns.

### CURRENT-FEEDBACK AMPLIFIER

#### Advantages:

- Fewer transistor stages (signal delay time).
- Shorter signal delay time = larger bandwidth.
- Small-signal bandwidth independent of gain compensation of the frequency response possible with feedback resistance instead of capacitance.
- Complementary-symmetric circuit technique improves large-signal performance.

#### Disadvantages:

- Low-impedance inverting input.
- Asymmetric differential inputs.
- Low common-mode rejection ratio.
- Relatively high input offset voltage.

### ADVANTAGES A CF-AMPLIFIER HAS WITH THE OPA660

The -3dB bandwidth stays constant over the entire modulation range up to  $\pm 2.5V$  and gains up to 12. Quiescent current control guarantees an excellent bandwidth /quiescent current ratio. See Figure 16.

$R_Q$  varies the quiescent current to produce the necessary bandwidth. Feedback resistances can optimize frequency response over a broad range. This configuration also provides excellent pulse behavior, even up to large pulse amplitudes. Burr-Brown offers the Current-Feedback Amplifier completely assembled as a small demo board under the part number DEM-OPA660-2GC.

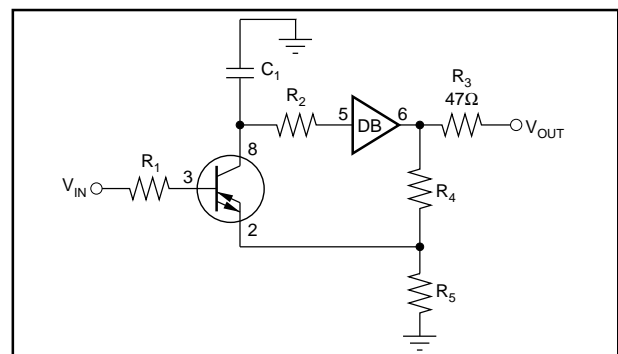

FIGURE 14. Current-Feedback Amplifier.

### DIRECT-FEEDBACK AMPLIFIER

Another interesting basic circuit with the OPA660 is the so-called Direct-Feedback Amplifier, Figure 15. The idea of using voltage feedback from the collector to the emitter for Current-Conveyor structures was suggested for the first time a few years ago, and even in test configurations with simple Current-Conveyor structures, this design demonstrated excellent RF features. We named this structure the Direct-Feedback Amplifier, due to its short feedback loop across the complementary current mirror. As shown in detail with the Current-Feedback Amplifier, the open-loop gain of the Direct-Feedback Amplifier varies according to the closed-loop gain. This relation causes the product of the open-loop gain,  $V_o$ , and feedback factor,  $k_o$ , to stay constant, while the bandwidth also remains independent of the adjusted total gain. The currents at the emitter and collector always flow in the same direction. The current from the collector across  $R_3$  causes an additional voltage drop in  $X_E$  and counteracts the base-emitter voltage. The reduced voltage difference, however, causes reduced current flow at the emitter and across the current mirror at the collector. It functions like double feedback and is adjusted by the ratio between  $R_3$  and  $X_E$ . The Diamond Buffer decouples the high-impedance output.

Burr-Brown offers the Direct-Feedback Amplifier completely assembled as a small demo board under the part number DEM-OPA660-3GC.

Figures 17 and 18 show the excellent test results with the Direct-Feedback Amplifier.

Using a quiescent current of 20mA and the given component values and compensation at the emitter, it is possible to attain 330MHz at  $\pm 100mV$  and max 550MHz at  $\pm 1.4V$  bandwidth. The frequency response curve is extremely flat and shows peaking of 1dB only with output signals of  $\pm 2.5V$ . The voltage gain  $G$  is 3. The pulse diagrams shown here for small-signal modulation illustrate the excellent pulse response. There is no difference in pulse response between 300mVp-p and 5Vp-p.

The calculated slew rate is 2500V/ $\mu s$  during 5Vp-p signals. Previously, this slew rate could only be achieved using hybrid circuits with a quiescent current between 20mA and 500mA and a voltage supply of  $\pm 15V$  for  $\pm 2.5V$  signals. See Table IV.

### FUNCTIONAL CIRCUITS WITH THE OPA660

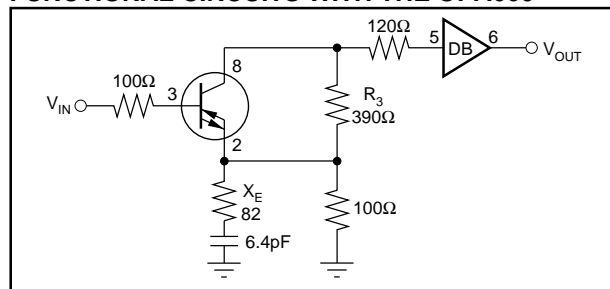

FIGURE 15. Direct-Feedback Amplifier.

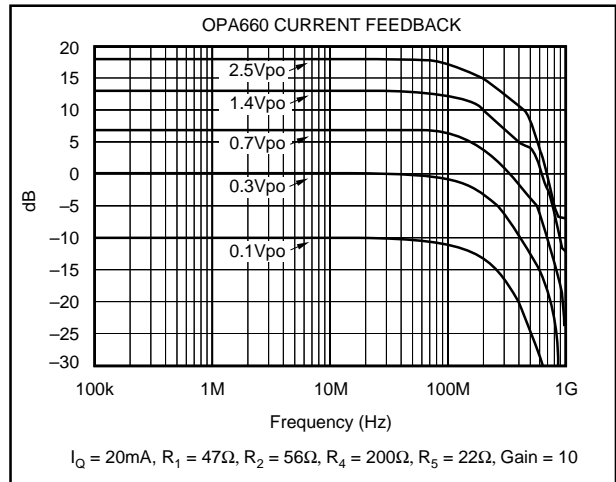

FIGURE 16. Current-Feedback Amplifier Frequency Response.

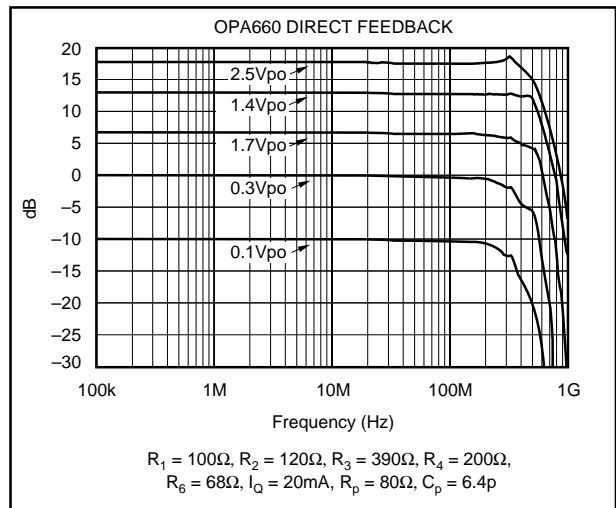

FIGURE 17. Direct-Feedback Amplifier Frequency Response.

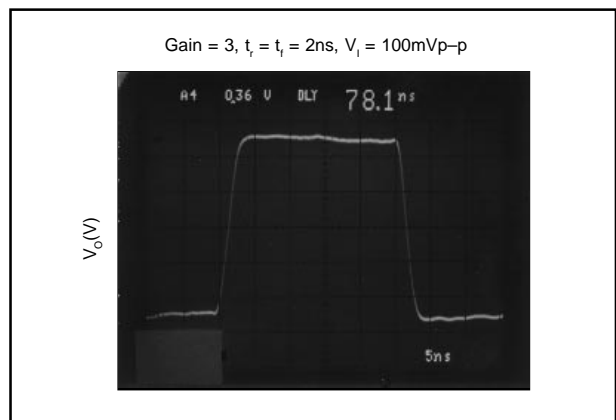

FIGURE 18. Pulse Behavior of the Direct-Feedback Amplifier.

$V_{OUT}$	$f_{-3dB}$
$\pm 100mV$	331MHz
$\pm 300mV$	362MHz
$\pm 700mV$	520MHz
$\pm 1.4V$	552MHz
$\pm 2.5V$	490MHz

TABLE IV. -3dB Bandwidth vs Output Voltage.

- Driver Circuits for Diodes Capacitive/Inductive Loads
- Operational Amplifiers
- Line Drivers
- Integrators/Rectifier Circuits
- Receiver Amplifier for Pin Diodes
- Active Filters

The new circuit technology really comes into full use, however, in applications in which the current is the actual signal. Such applications include active filters with Current-Conveyor structures, control of LED and laser diodes, as well as control of tuning coils, driver transformers, and magnetic heads for analog and digital video recording.

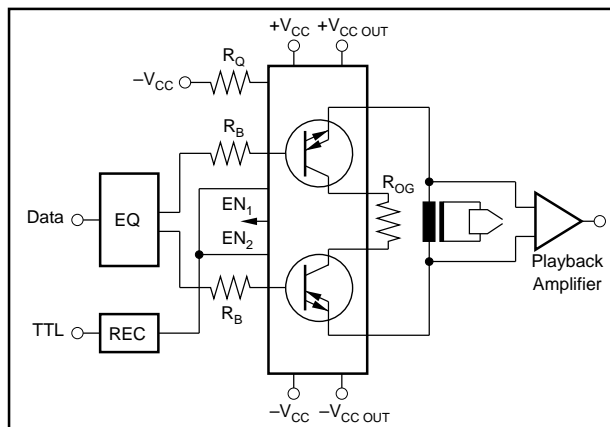

FIGURE 19. Video Record Amplifier.

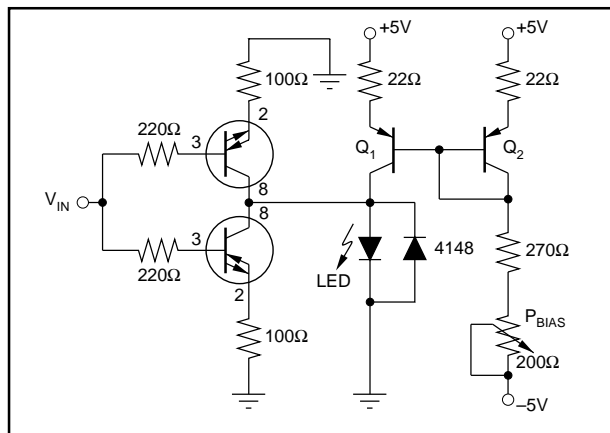

FIGURE 20. Wideband LED Transmitter.

## VIDEO RECORD AMPLIFIER

A good way to see the advantages of current control over voltage control is to compare them when driving magnetic heads in video technology. Analog recording requires high linearity, while digital recording demands sharp edges and low phase distortion, since the zero crossing point contains the relevant information.

A special recording amplifier is necessary to drive the rotating video heads. This amplifier, Figure 19, delivers the current to magnetize the tape. The recording current can be between 1mA and 60mA, depending upon the amplitude, type of recording, and type of tape used. The current flowing through the video heads must be independent of the frequency and load. Current source control can deliver current through the load up to the rated output limit, independent of the voltage drop. In addition, the recording current is directly proportional to the magnetic field intensity and flux density. The record drive amplifier for digital signals shown here functions in a bridge configuration, in which the inverting and non-inverting digital data streams control the signal differentially. Bridge operation, and thus a doubled voltage range, is necessary because the voltage drop across the load inductance exceeds the voltage range of the Diamond Transistor at the 30MHz recording rate and maximum record current. The common emitter resistor allows simple adjustment of the transconductance.

In previous amplifiers, relays separated the replay and record amplifiers when switching from recording to replay. Using the OPA660 or the OPA2662, which contains two Diamond Transistors with high-current output stages, the  $I_O$  (OPA660) or EN inputs (OPA2662) can switch the record drive amplifier into high-impedance mode. The gate in front of the output stage stops the digital data stream. In high-impedance mode, the output stage requires very little current.

## DRIVER AMPLIFIER FOR LED TRANSMISSION DIODES

The advantages of current control also become apparent when driving light-emitting diodes and laser diodes in analog/digital telecommunications and in test procedures with modulated laser light. Using the OPA2662, it will be possible to control laser diodes by a complementary-bipolar current source; using the OPA660, it is already possible to control LEDs with  $\pm 30mA$  drive current. Figure 20 shows the circuit implementation. The quiescent current is 20mA max when  $R_O = 220\Omega$ , and the inputs of both emitter followers, which are not illustrated in the Figure, are grounded through 220Ω resistances, since these inputs are not necessary in this application. The current mirror consisting of  $Q_1$  and  $Q_2$  sets the quiescent current for the LED, which can then be adjusted by  $P_{BIAS}$ . Two Diamond Transistors wired parallel to each other deliver the signal current. Diamond Transistors can be connected to each other at the collector output to increase the output current, which has already increased to  $\pm 30mA$  in this configuration. The diode 4148 protects the transmitter diodes against excessive reverse voltages.

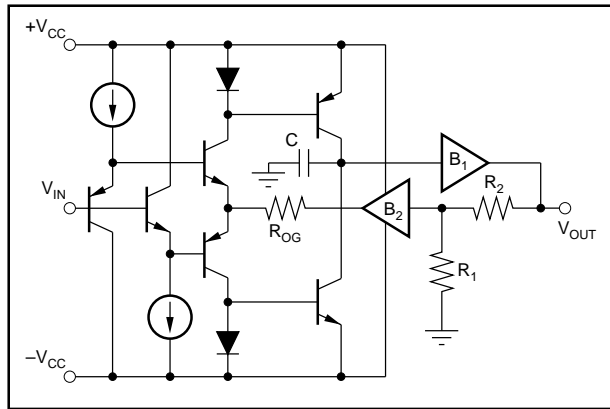

FIGURE 21. Voltage-Feedback Amplifier.

### OPERATIONAL AMPLIFIER WITH VOLTAGE FEEDBACK IN DIAMOND STRUCTURE

The disadvantages of the Current-Feedback Amplifier listed above are unbalanced inputs, low-impedance inverting input, poor common-mode rejection ratio, and size of the input offset voltage. Now, we would like to present a concept which integrates the Diamond structure with voltage feedback in one circuit. An additional buffer transforms the current feedback of the Current Feedback Amplifier into voltage feedback. Figures 21 and 22 illustrate the circuit diagram and the extended Voltage-Feedback Amplifier. The feedback buffer is identical to the input section of the Diamond Transistor and forms one side of the differential amplifier, while the Diamond Transistor is the other side. Both buffer outputs are connected to  $R_{OG}$ , which determines the open-loop gain and corresponds to the emitter degeneration resistor of a conventional differential stage.

The output of this differential stage is the collector of the Diamond Transistor, which is driven in quasi open-loop mode due to the output buffer. Both inverting and non-

inverting operations are possible. The ratio of the feedback resistances determines the closed-loop gain, and the user can attain optimum frequency response by adjusting the open-loop gain externally with  $R_{OG}$ . The frequency response of the differential amplifier is equivalent to that of a 2nd order low-pass Butterworth filter with gain. Due to the additional delay time in the control loop caused by the feedback buffer, the frequency response is poorer than the current feedback by 30%. The OPA622, which was recently introduced, contains a Diamond Transistor and two buffers. With the output current capability of  $\pm 100\text{mA}$ , this IC can drive several low-impedance outputs. The output buffer has its own supply voltage pins to decouple the output stage from differential stage and to enable external current limitation. Because of the identical high-impedance inputs, the typical offset voltage at the output is  $\pm 1\text{mV}$ , and the common-mode rejection ratio is over 70dB. These values are excellent results for RF amplifiers.

### DRIVER AMPLIFIER FOR LOW-IMPEDANCE TRANSMISSION LINES

The ability of the Current-Feedback Amplifier to deliver  $\pm 15\text{mA}$  output current makes it a good choice as a driver amplifier for low-impedance ( $50\Omega/75\Omega$ ) coaxial transmission lines. To transmit the pulse free of reflections, the transmission line must be terminated on both sides by the characteristic impedance of the line. A resistance in series to the output resistance of the driver amplifier, Figure 23, matches the output of the amplifier to the line. The total resistance of the output and series resistors should be equal to the characteristic impedance. The output resistance of operational amplifiers rises with increasing frequency. Thus, the impedances are no longer matched and reflections arise due to high-frequency components in the signal. The output resistance of Current-Feedback Amplifiers rises, for example, up to  $25\Omega$  at 50MHz.

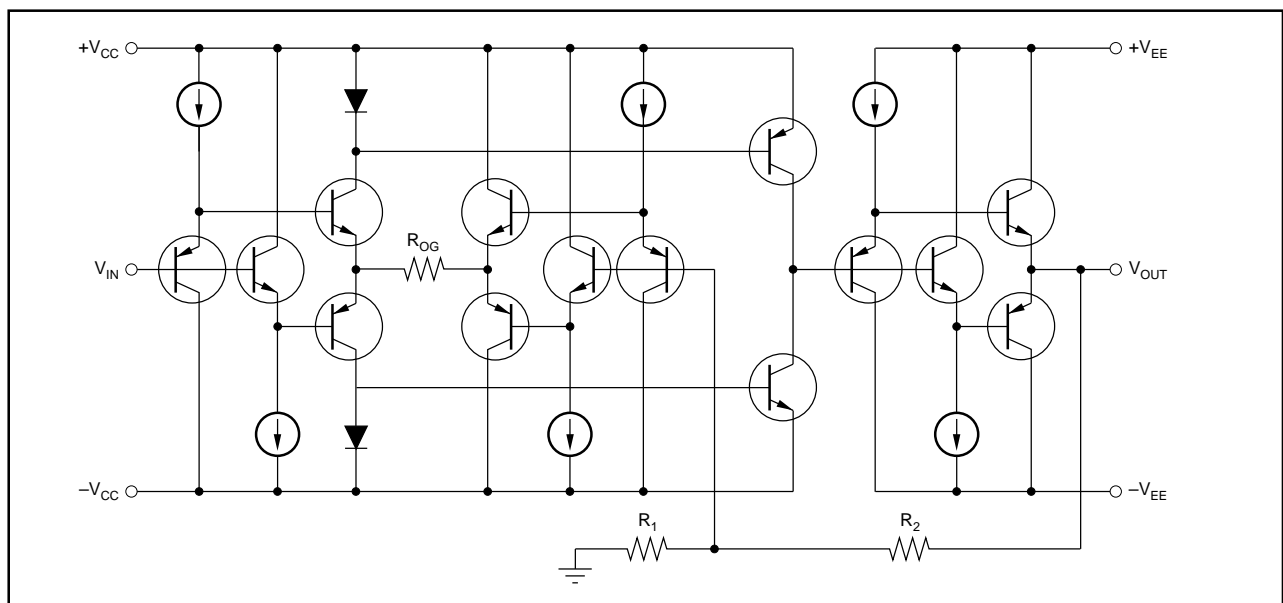

FIGURE 22. Extended Voltage-Feedback Amplifier.



## DIFFERENTIAL OUTPUT

The circuit in Figure 24 is well suited to applications with larger dynamic ranges, which require a differential output to drive triax lines. A signal amplitude of  $\pm 5V$  is provided to drive a load which is not grounded. The load could be the input resistance of an RF device in an EMC contaminated environment. Resistances in series to each amplifier output match the output to the line. These resistances are selected at somewhat less than half of the characteristic impedance. While the rise/fall time and bandwidth do not change, the slew rate doubles.

## MONOCHROMATIC MATRIX OR B/W HARDCOPY OUTPUT AMPLIFIER

The inverting amplifier in Figure 25 amplifies the three input voltages, which correspond to the luminance section of the RGB color signal. Different feedback resistances weight the voltages differently, resulting in an output voltage consisting of 30% of the red, 59% of the green, and 11% of the blue section of the input voltage. The way in which the signal is weighted corresponds to the transformation equation for converting RGB pictures into B/W pictures. The output signal is the black/white replay. It might drive a monochrome control monitor or an analog printer (hardcopy output).

## OPERATIONAL TRANSCONDUCTANCE AMPLIFIER (OTA)

The Diamond Transistor and Diamond Buffer form a differential amplifier with two symmetric high-impedance inputs with current output. This amplifier is also known as the Operational Transconductance Amplifier, Figure 26. In this application,  $R_E$  sets the open-loop gain. The bipolar current output can be connected to a discrete cascode transistor, which enables wideband and high voltage outputs.

## NANOSECOND INTEGRATOR

One very interesting application using the OPA660 in physical measurement technology is a non-feedback ns-integrator, Figures 27 and 28, which can process pulses with an amplitude of  $\pm 2.5V$ , have a rise/fall time of as little as 2ns, and pulse width of more than 8ns. The voltage-controlled current source charges the integration capacitor linearly according to the following equation:

$$V_C = V_{BE} \cdot gm \cdot t/C$$

$V_C$  = Voltage At Pin 8

$V_{BE}$  = Base-Emitter Voltage

gm = Transconductance

t = Time

C = Integration Capacitance

The output voltage is the time integral of the input voltage. It can be calculated from the following equation:

$$V_O = \frac{gm}{C} \int_0^T V_{BE} dt$$

$V_O$  = Output Voltage  
 $T$  = Integration Time  
 $C$  = Integration Capacitance

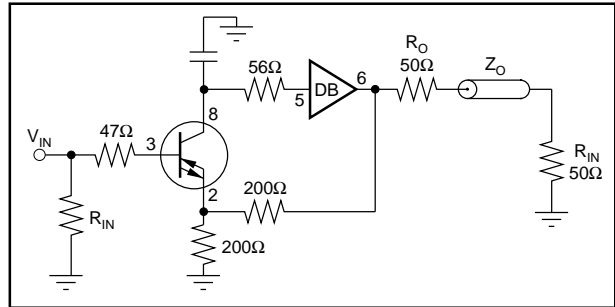

FIGURE 23. 50Ω Driver Amplifier.

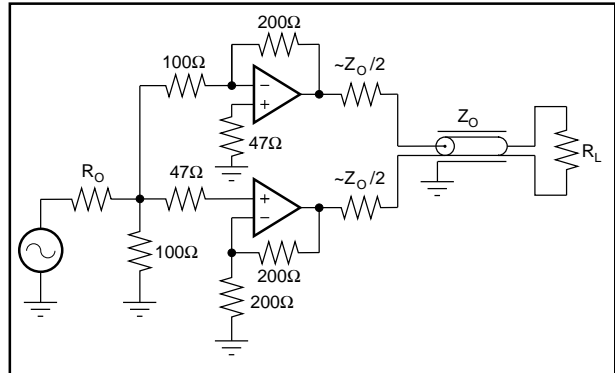

FIGURE 24. Balanced Driver.

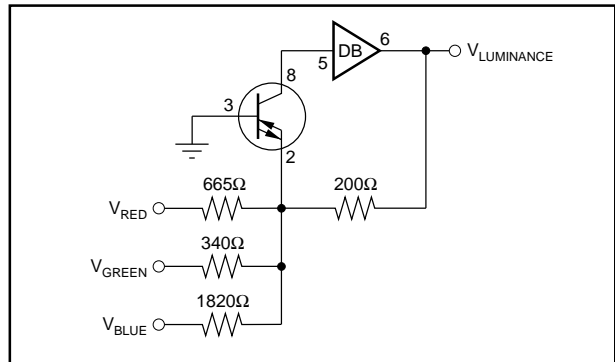

FIGURE 25. Monochrome Amplifier.

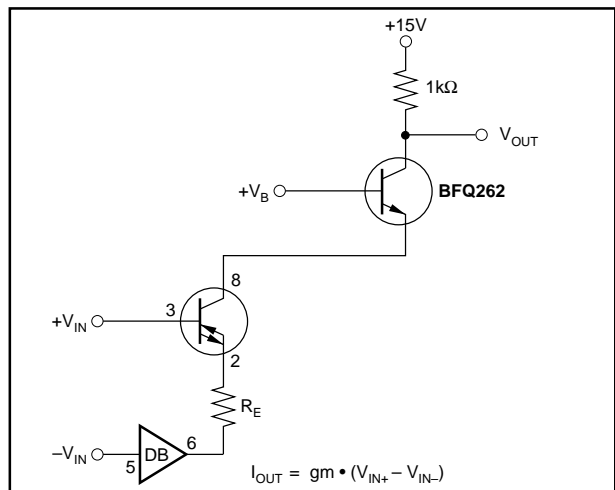

FIGURE 26. Operational Transconductance Amplifier.

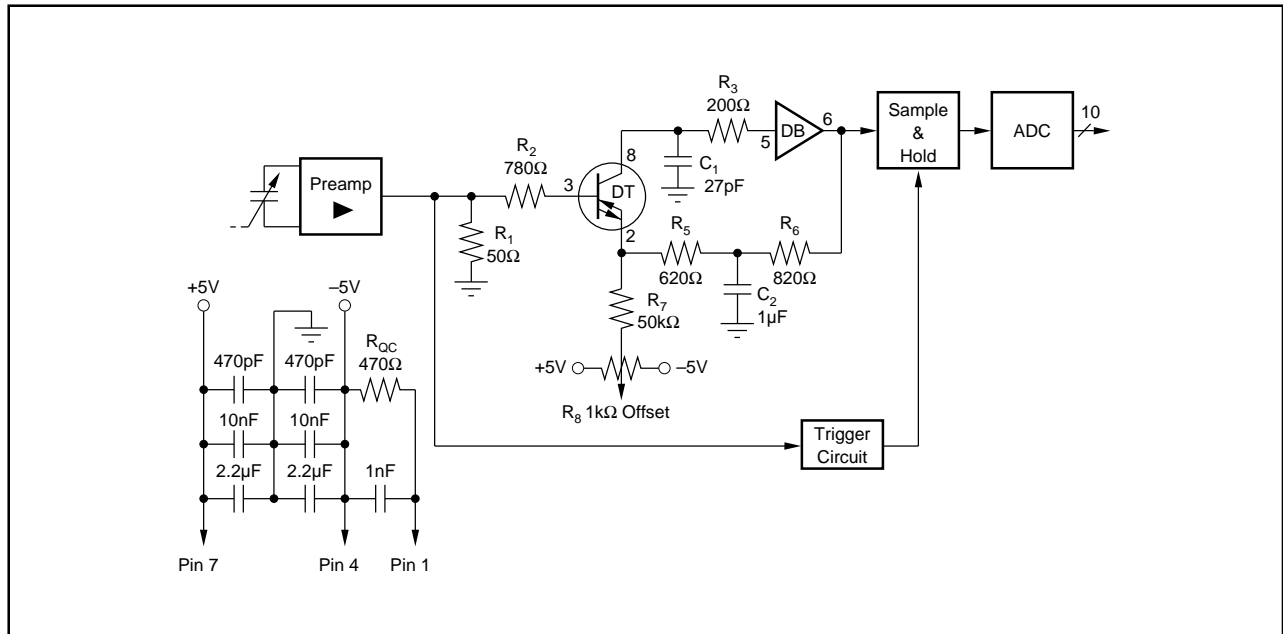

FIGURE 27. Nanosecond Integrator.

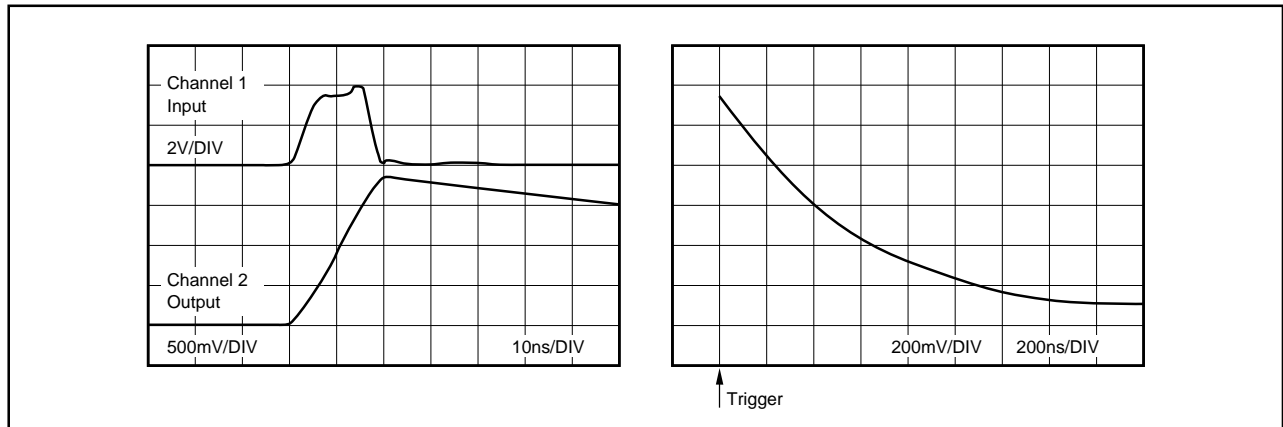

FIGURE 28. Integrator Performance.

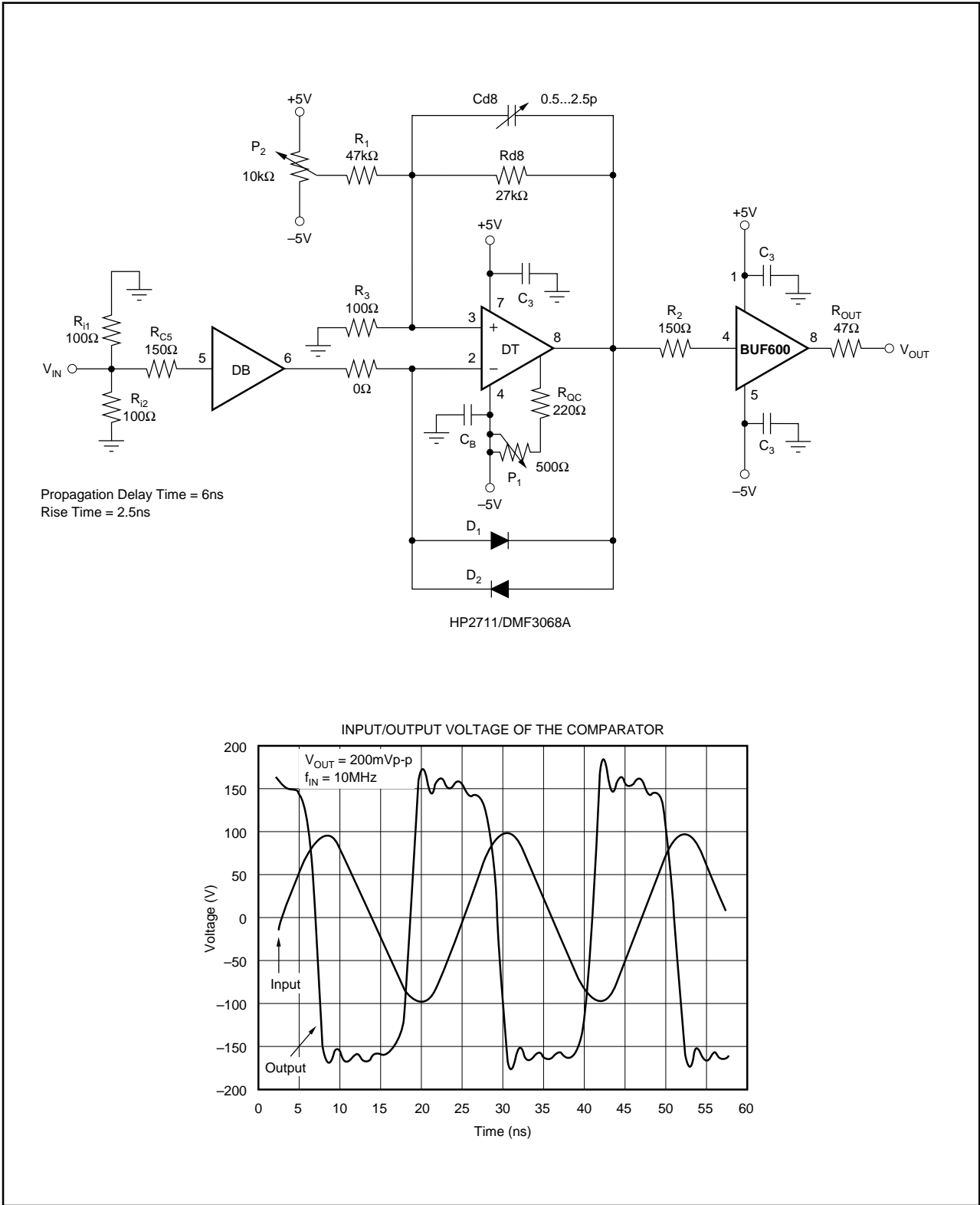

FIGURE 29. Comparator (Low Jitter).

## COMPARATOR

An interesting and also cost effective circuit solution using the OPA660 as a low jitter comparator is illustrated in Figure 29. This circuit uses, at the same time, a positive and negative feedback. The input is connected to the inverting E-input. The output signal is applied in a direct feedback over the two antiparallel connected gallium-arsenide diodes back to the emitter. A second feedback path over the RC combination to the base, which is a positive feedback, accelerates the output voltage change when the input voltage crosses the threshold voltage. The output voltage is limited to the threshold voltage of the antiparallel diodes. The diagram on the right side of Figure 29 demonstrates the low jitter performance of the presented comparator circuit.

## RECTIFIER FOR RF SIGNAL IN THE mV RANGE

Previously, rectifier diodes were included in the feedback loop of operational amplifier circuits to form ideal diodes for accurate detection of small signals in the mV range. In this configuration, the slew rate of the operational amplifier fixes the maximum frequency which can be rectified. The circuit in Figure 30 illustrates a new method of rectifying RF signals. The diodes at the current source output direct the current either into the load resistance or toward ground. The output current is zero even during zero crossing, resulting in a very soft transfer from one diode to the next.

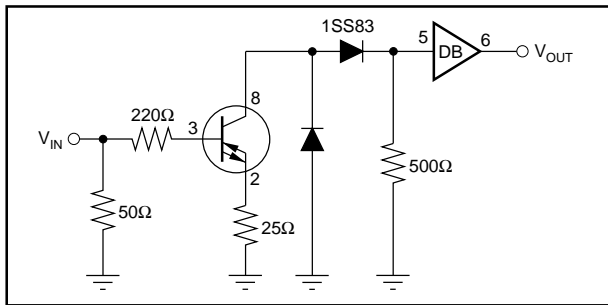

FIGURE 30. RF Rectifier.

The current source compensates for different voltage drops across the diodes up to its maximum rated voltage. It is possible to extend this circuit to a full-wave rectifier by connecting the second diode, instead to GND, over a resistor to GND, to rectify the negative half of the input signal.

## CONTROLLING THE GAIN BY ADJUSTING THE BIAS CURRENT

The transfer curve of the Diamond Transistor demonstrates that the transconductance varies according to the quiescent current. The circuit, Figure 31, described here uses this relation to control the gain. As measurements have shown, it is possible to produce a gain range of 20dB, but the minimum quiescent current should not fall short of 1mA. Quiescent currents smaller than 0.5mA increase the non-linearities to a value which can no longer be tolerated. A positive current flowing into the  $I_Q$ -adjust (pin 1) disables the OPA660, the output of which goes into high-impedance state. The switch-on period lasts only a few ns, while the switch-off time is several  $\mu$ s. The internal capacitances are discharged at different speeds according to the load. The possibility of modulating the bias current dynamically has not yet been investigated. But based on the internal configuration, modulation frequencies up to several kHz should be possible.

## PIN DIODE RECEIVER

Figure 32 illustrates a preamplifier which can recover both analog and digital signals for a fiber optic receiver. This preamplifier can amplify weak and noisy signal currents and convert them into voltage. In this arrangement, the Diamond Transistor operates in the inverting base configuration, which functions excellently in this application due to its low-impedance current input. In the ideal case, the voltage set at the base by the voltage divider appears at the low-impedance emitter free of offset errors. The voltage drop above the

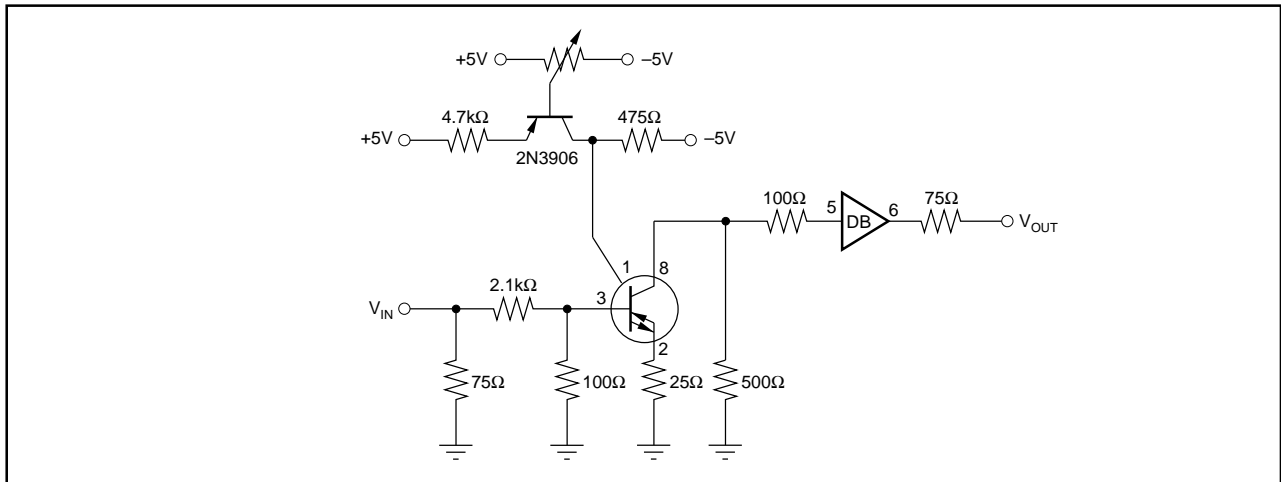

FIGURE 31. Controlled Amplifier.

diode is adjusted to zero volts. During exposure to light, the pin diode functions as a high-impedance current source and either delivers current to the emitter or removes current. The resulting voltage difference between the base and emitter controls the collector current. The current gain error is dependent both upon the dynamic output resistance of the pin diode and upon the transconductance of the Diamond Transistor. It is possible to achieve current gain factors of 200 to 400, depending upon the diode and quiescent current used. Advantages of this circuit structure include the following points:

- The transconductance and speed of the Diamond Transistor keep the voltage drop across the diode low, preventing the diode capacitance from increasing with the modulation.
- A fixed voltage across the diode improves the linearity, since the sensitivity of the diode varies with diode voltage.
- The capacitance at the emitter is only 2pF.
- The signal path is short, resulting in a very wide bandwidth.

### ACTIVE FILTERS USING THE OPA660 IN CURRENT CONVEYOR STRUCTURE

One further example of the versatility of the Diamond Transistor and Buffer is the construction of active filters for the MHz range. Here, the Current Conveyor structure, Figure 33, is used with the Diamond Transistor as a Current Conveyor.

The method of converting RC circuit loops with operational amplifiers in Current Conveyor structures is based upon the

adjoint network concept. A network is reversible or reciprocal when the transfer function does not change even when the input and output have been exchanged. Most networks, of course, are nonreciprocal. The networks, Figure 34, perform interreciprocally when the input and output are exchanged, while the original network,  $N$ , is exchanged for a new network  $N_A$ . In this case, the transfer function remains the same, and  $N_A$  is the adjoint network. It is easy to construct an adjoint network for any given circuit, and these networks are the base for circuits in Current-Conveyor structure. Individual elements can be interchanged according to the list in Figure 35. Voltage sources at the input become short circuits, and the current flowing there becomes the output variable. In contrast, the voltage output becomes the input, which is excited by a current source. The following equation describes the interreciprocal features of the circuit:  $V_{OUT}/V_{IN} = I_{OUT}/I_{IN}$ . Resistances and capacitances remain unchanged. In the final step, the operational amplifier with infinite input impedance and  $0\Omega$  output impedance is transformed into a current amplifier with  $0\Omega$  input impedance and infinite output impedance. A Diamond Transistor with the base at ground comes quite close to an ideal current amplifier. The well-known Sallen-Key low-pass filter with positive feedback, Figure 36, is an example of conversion into Current-Conveyor structure. The positive gain of the operational amplifier becomes a negative second type of Current Conveyor (CCII), Figure 37. Both arrangements have identical transfer functions and the same level of sensitivity to deviations. The most recent implementation of active filters in a Current-Conveyor structure produced a second-order Bi-Quad filter. The value of the resistance in the emitter of the Diamond Transistor controls the filter characteristic.

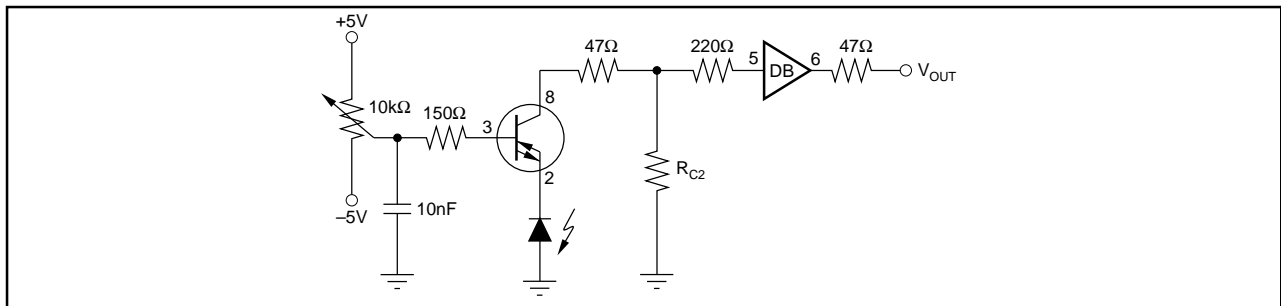

FIGURE 32. Preamplifier.

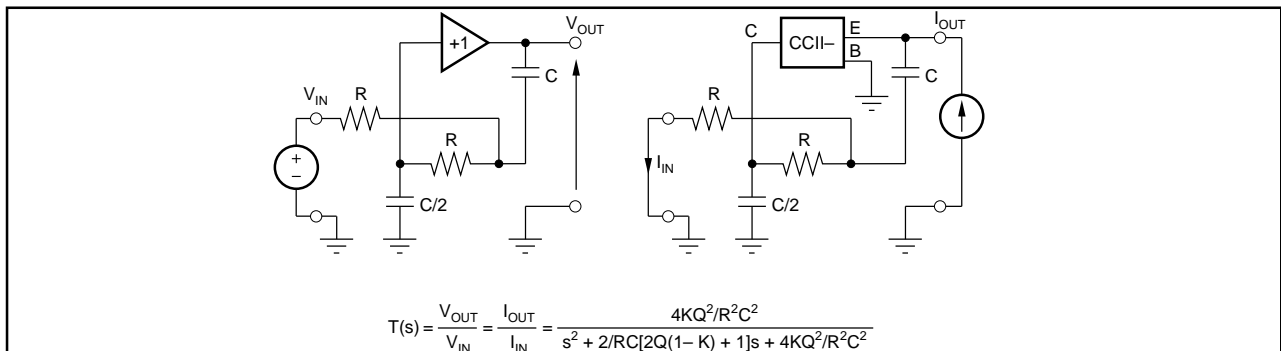

FIGURE 33. Current Conveyor.

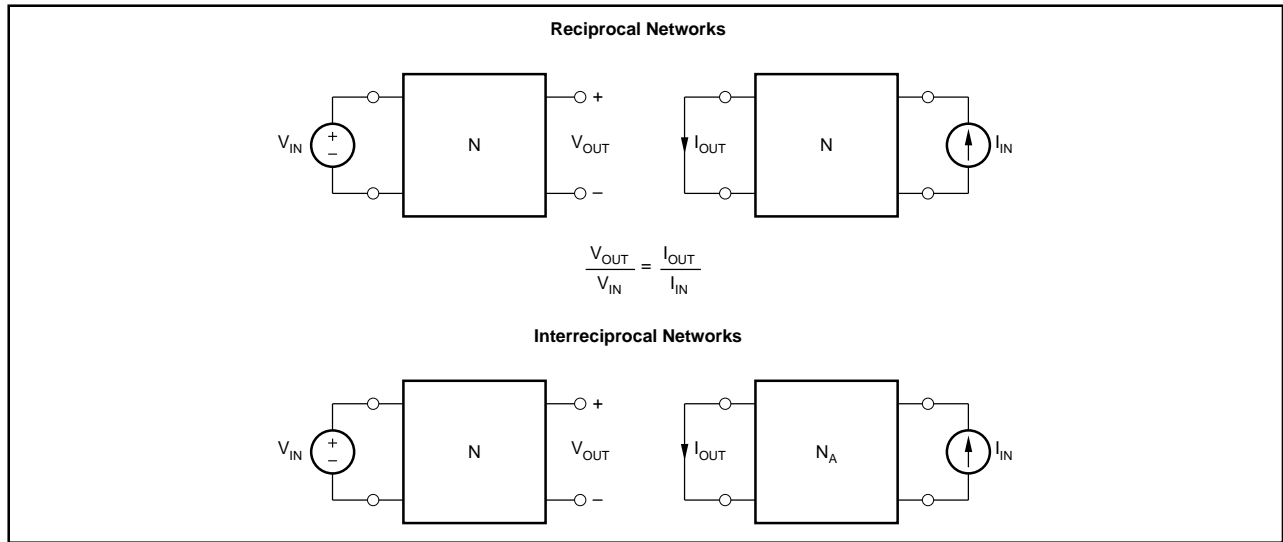

FIGURE 34. Networks.

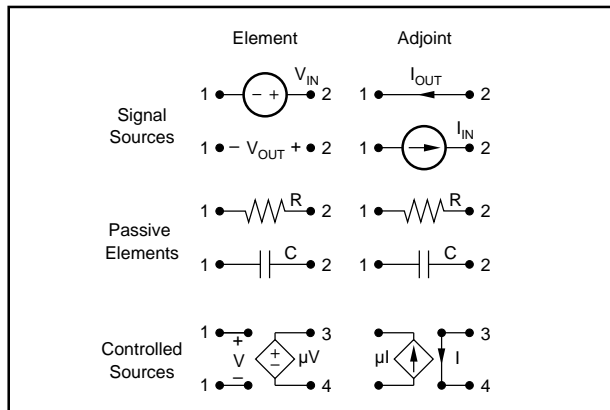

FIGURE 35. Individual Elements in the Current Conveyor.

**TRANSFER FUNCTION**

$$F(p) = \frac{V_{OUT}}{V_{IN}} = \frac{S^2 C_1 R_{1M} \frac{R_{2M}}{R_3} + s C_1 \frac{R_{1M}}{R_2} + \frac{1}{R_1}}{S^2 C_1 C_2 R_{1M} \frac{R_{2M}}{R_{3S}} + s C_1 \frac{R_{1M}}{R_{2S}} + \frac{1}{R_{1S}}}$$

**FILTER CHARACTERISTICS**

- Low-pass filter:  $R_2 = R_3 = \infty$
- High-pass filter:  $R_1 = R_2 = \infty$
- Bandpass filter:  $R_1 = R_3 = \infty$
- Band rejection filter:  $R_2 = \infty; R_1 = R_3$
- All-pass filter:  $R_1 = R_{1S}, R_2 = R_{2S}, R_3 = R_{3S}$

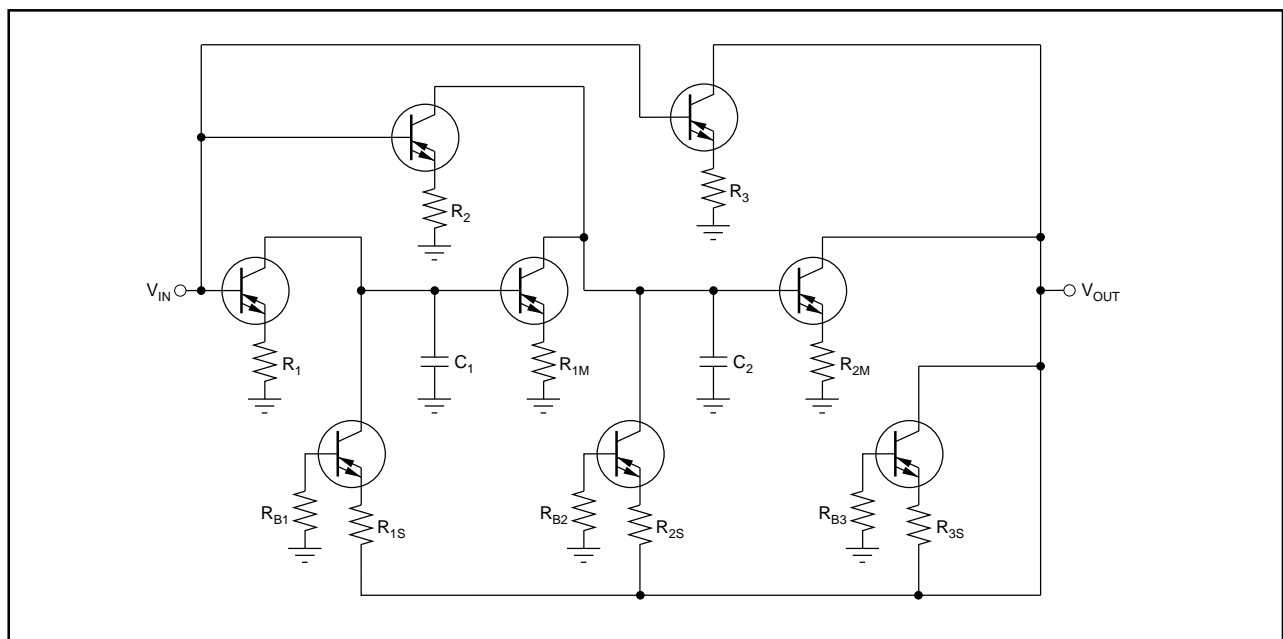

FIGURE 36. Universal Active Filter.

The design of a low-pass filter with a corner frequency of 30MHz results in the following values:

$$R_{1M} = R_{2M} = 91\Omega; C_1 = C_2 = 100\text{pF}$$

$$R_1 = 142\Omega; R_{1S} = 161\Omega; R_{2S} = 140\Omega; R_{3S} = 426\Omega$$

Figure 37 illustrates the frequency response and phase characteristics of the filter. Advantages of active filters in a Current Conveyor structure:

- The increase in output resistance of operational amplifiers at high frequencies makes it difficult to construct feedback filter structures (decrease in stop-band attenuation).
- All filter coefficients are represented by resistances, making it possible to adjust the filter frequency response without affecting the filter coefficients.
- The capacitors which determine the frequency are located between the ground and the current source outputs and are thus grounded on one side. Therefore, all parasitic capacitances can be viewed as part of these capacitors, making them easier to comprehend.
- The features which determine the frequency characteristics are currents, which charge the integration capacitors. This situation is similar to the transfer characteristic of the Diamond Transistor.

#### OPTIMIZATION WITH DIAMOND STRUCTURE

- AGC Amplifier
- DC-Restored Amp
- Analog Multiplexer
- PLL
- Sample/Hold
- Multiplier
- Oscillators
- RF-Instrumentation Amplifiers

#### DYNAMIC OUTPUT IMPEDANCE INCREASE

As illustrated in Table II, the output impedance of the OTA at a quiescent current of  $\pm 20\text{mA}$  equals to  $25\text{k}\Omega \parallel 4.2\text{pF}$ . The

lower curve in the diagram on the right half of Figure 38 shows the behavior of the output impedance vs frequency. For some applications, like the integrator for ns-pulses of Figure 27, the relatively low output impedance is a real disadvantage. The fast discharge of the integration capacitor after (Figure 28) the pulse is over demonstrates this behavior. An easy way to improve the output impedance is a positive feedback path formed by the resistor divider from the collector to the base and the GND. The ratio of the two resistors determines the final output impedance, which can even be made negative. The capacitor between C and B supports the improvement vs frequency, which is illustrated in the diagram of Figure 38. The positive feedback results in a dynamic increase of the open loop gain, which can be made higher than 110dB.

#### DIFFERENTIATOR FOR WEAK AND DISTURBED DIGITIZED SIGNALS

As it is shown in Figure 39 a RC network can be connected between the E-output of the OTA and buffer output. The proposed circuit improves the pulse shape of digitized signals coming from a magnetic tape or a hard disc drive.

#### CONTROL LOOP AMPLIFIER

A new type of control loop amplifier for fast and precise control circuits can be designed with the OPA660. The circuit of Figure 40 shows a series connection of two voltage control current sources which have an integral and at higher frequencies a proportional behavior vs frequency. The control loop amplifiers show an integrator behavior from DC to the frequency, represented by the RC time constant of the network from the C-output to GND. Above this frequency they operate as an amp with constant gain. The series connection increases the overall gain to about 110dB and thus minimizes the control loop deviation. The differential configuration at the inputs enables one to apply the measured output signal and the reference voltage to two identical high-impedance inputs. The output buffer decouples the C-output of the second OTA in order to insure the AC-performance and to drive subsequent output stages.

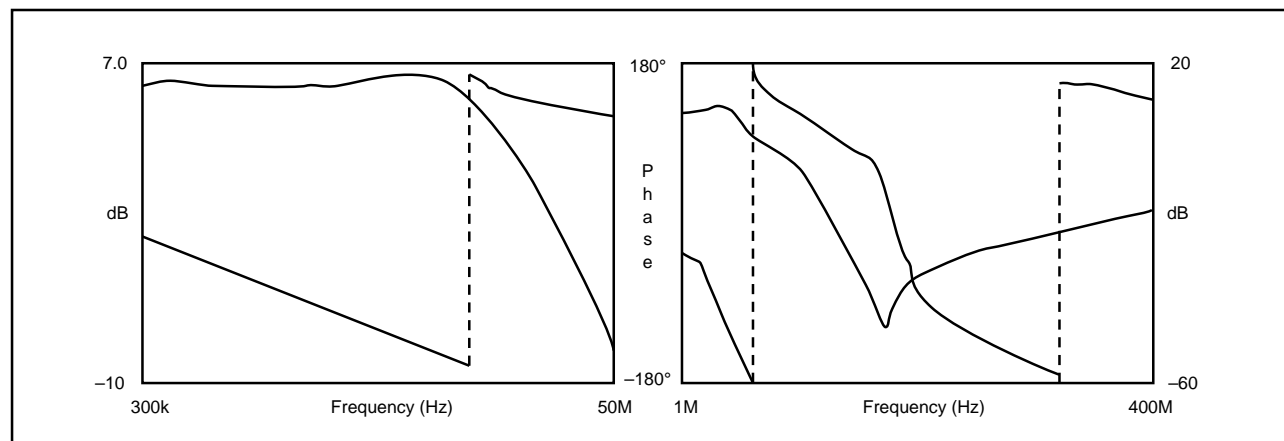

FIGURE 37. Current Conveyor LP.

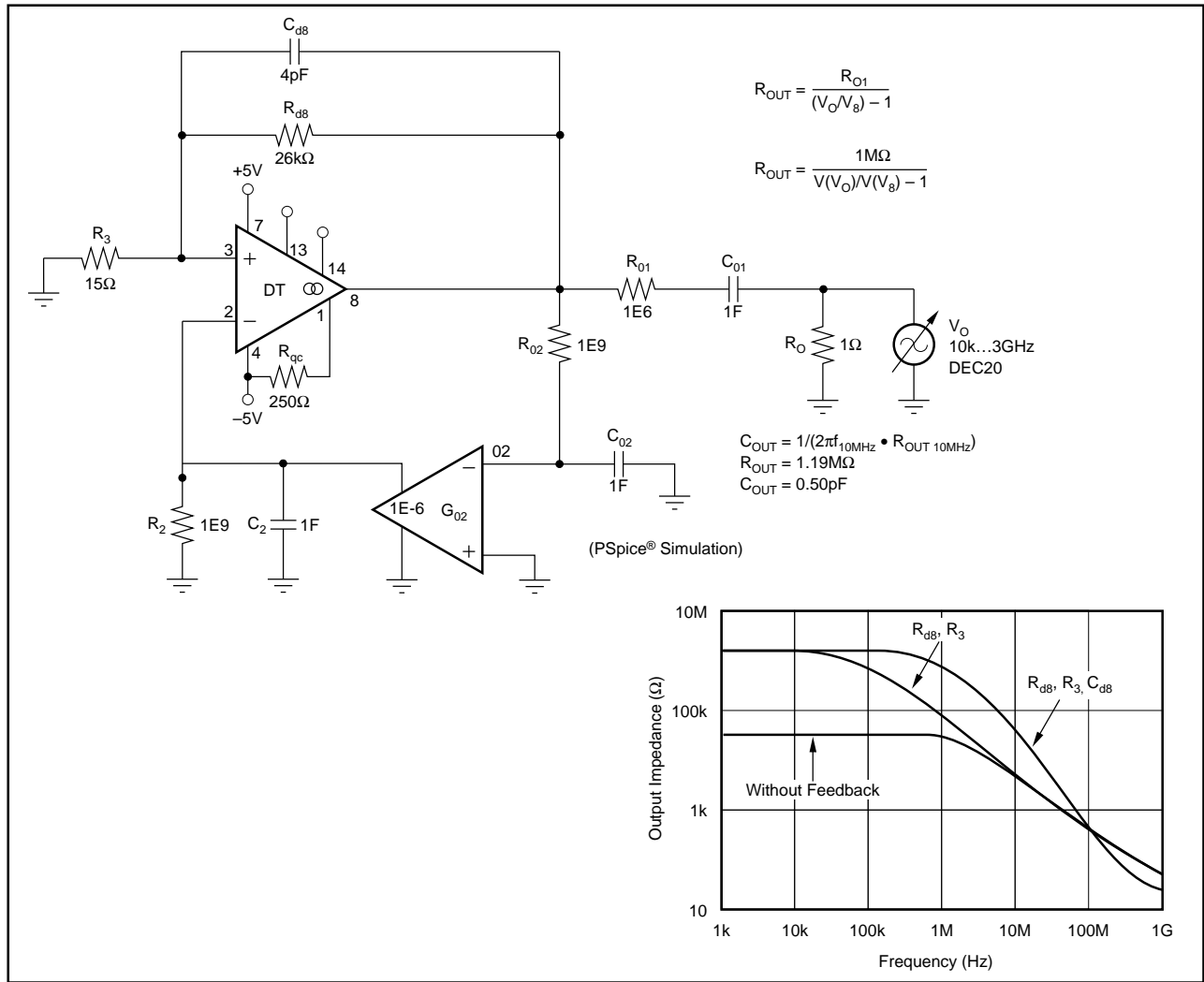

FIGURE 38. Transconductance Output Impedance (Dynamic increase with positive feedback).

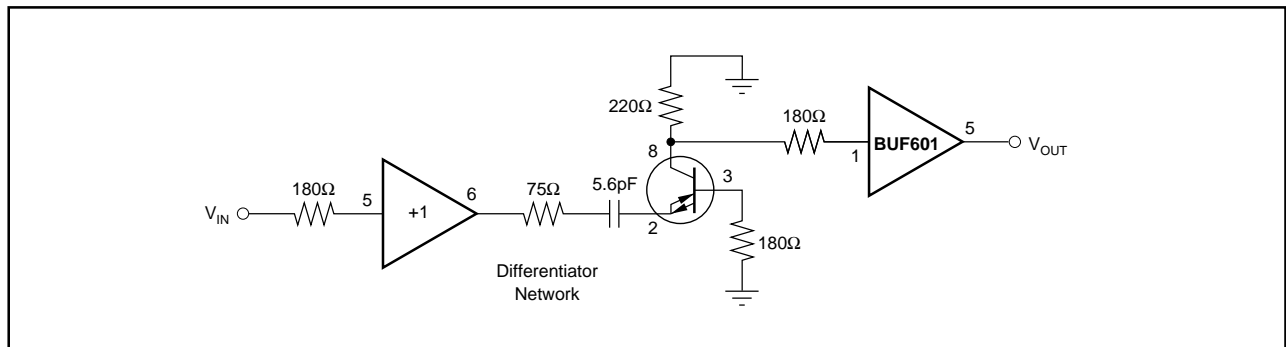

FIGURE 39. Differentiator for Digitized Video Signals.



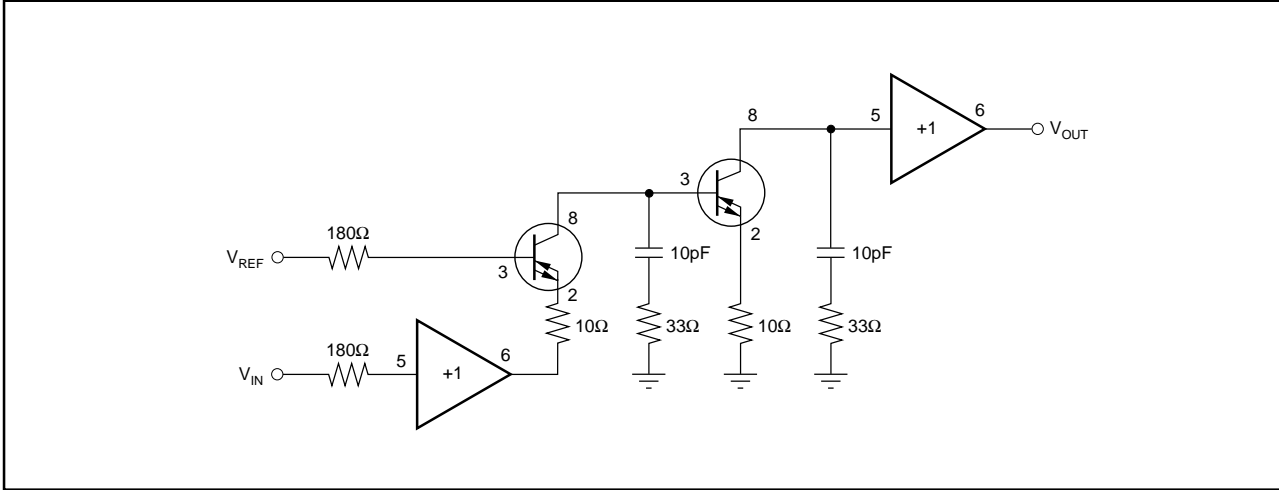

FIGURE 40. Control Loop Amplifier.